

Digital control range for
extraction steam turbines

Si-TEC³ CGC-ET

DATA SHEET

Model

CGC-ET
Controlled Extraction Turbines

Overview

Si-TEC 3 is the world's only digital governor with fully integrated generator functions including automatic synchronising, load control (kW) & sharing and kVAR/PF control & sharing.

Developed over the last 30+ years HEINZMANN Australia has forged the way with our unique integrated control philosophy, which empowers customers worldwide in unlocking the full potential of their Steam Turbine Generator (STG) operating capabilities.

These integrated functions significantly improve the operator's ability to bring the STG on-line in a faster and safer manner than ever before which in turn increases the STGs availability and effectiveness.

This integrated approach lowers STG down time through enhanced diagnostics enabling engineers to access real-time data which is consolidated in one location.

Both Island Isochronous Mode control and Grid Parallel load control are far superior when utilising this integrated system due to the Si-TEC's ability to process multiple control functions simultaneously and seamlessly throughout all control modes in basic as well as complex power generation applications.

The Si-TEC CGC-ET is designed for use with a wide range of single extraction STGs, either condensing or backpressure turbine applications.

With a growing number of global customers, Heinzmann Australia invites you to join this network of cutting edge technology.



Key Features

Precise speed governing

Dual Speed Sensor for redundancy

Wide range of PIDs

Interfacing with a wide range of AVR systems

Auto synchronising

kW control & load share

kVAR/PF control & load share

Extraction control (pressure or flow)

Flexible configuration

User-friendly tuning software (pcTune)

Extensive system diagnostics

Optional I/O expansion

Built-in SD Card with dual dynamic logging

Trip and alarm event recording

Ethernet communications

Real-time clock synchronising

Features

- Precise speed governing typically within 0.1% of operating (rated) speed at steady state
- Redundant software configurable speed sensors (MPU or proximity)
- Automatic actuator feedback calibration for Heinzmann actuators
- Automatic start/stop sequence initiated by a single logic input
- Start sequence based on either turbine temperature, shut down timeout or digital input selection
- Capable of driving a wide range of actuators including electro-hydraulic (eg. 0-200mA, 4-20mA, 0-5V etc) and all-electric actuators with position feedback (eg. Heinzmann)
- Multi-point linearisation curves (HP & LP actuators)
- Multiple and wide range PIDs (includes 6 x speed PIDs, kW PID, process PID, voltage bias control, synchronising control, kVAr/PF control etc)
- CAN bus interface with PCU module (driving LP actuator for controlled extraction)
- Expansion of existing I/O for logic outputs, relay outputs, analog inputs & outputs
- 3-phase AC RMS voltage and current sensing
- Configurable alarms can be multi-functional

- Bump feature to optimise tuning of governor
- Graphical display (via pcTune) of Live live stream map and control overview (speed & extraction control)
- Accumulated data recording of turbine running hours, kW hours, kVAr hours etc)
- Extensive diagnostic functions
- Turbine monitoring via ONYX HMI touchscreen

Application Range

- Power generation applications where up to 24 generators can be paralleled together. Multiple groups can be combined via GSM (Generator System Master) modules.
- Single or multiple GSMs for more complex applications, eg, multiple bus and/or feeders and applications for more than 24 nodes
- Co-generation operation – parallel to the grid for:
 - Soft “bumpless” transfer of loads
 - Peak shaving – set max. limit for import power
 - Base Loaded to the grid
 - Export excess power to the grid
 - Prime power - only export to grid
- Systems requiring high quality power based upon precise frequency and calculations of active and reactive power
- Generating sets in power stations, sugar mills, paper mills, petro-chemical and other bio-mass process industries, mining sites as well as the oil & gas industry.

Si-TEC³ CGC-ET System Overview

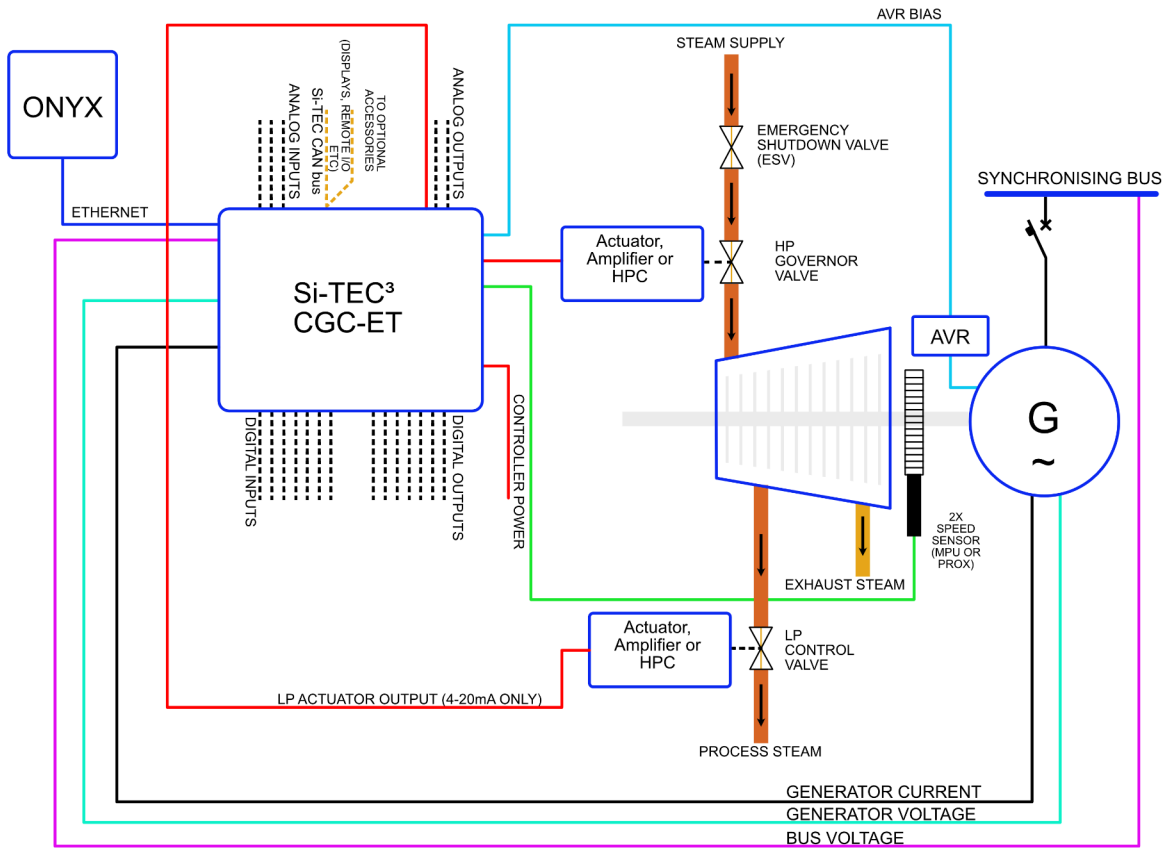

Si-TEC³ CGC-ETX System Overview

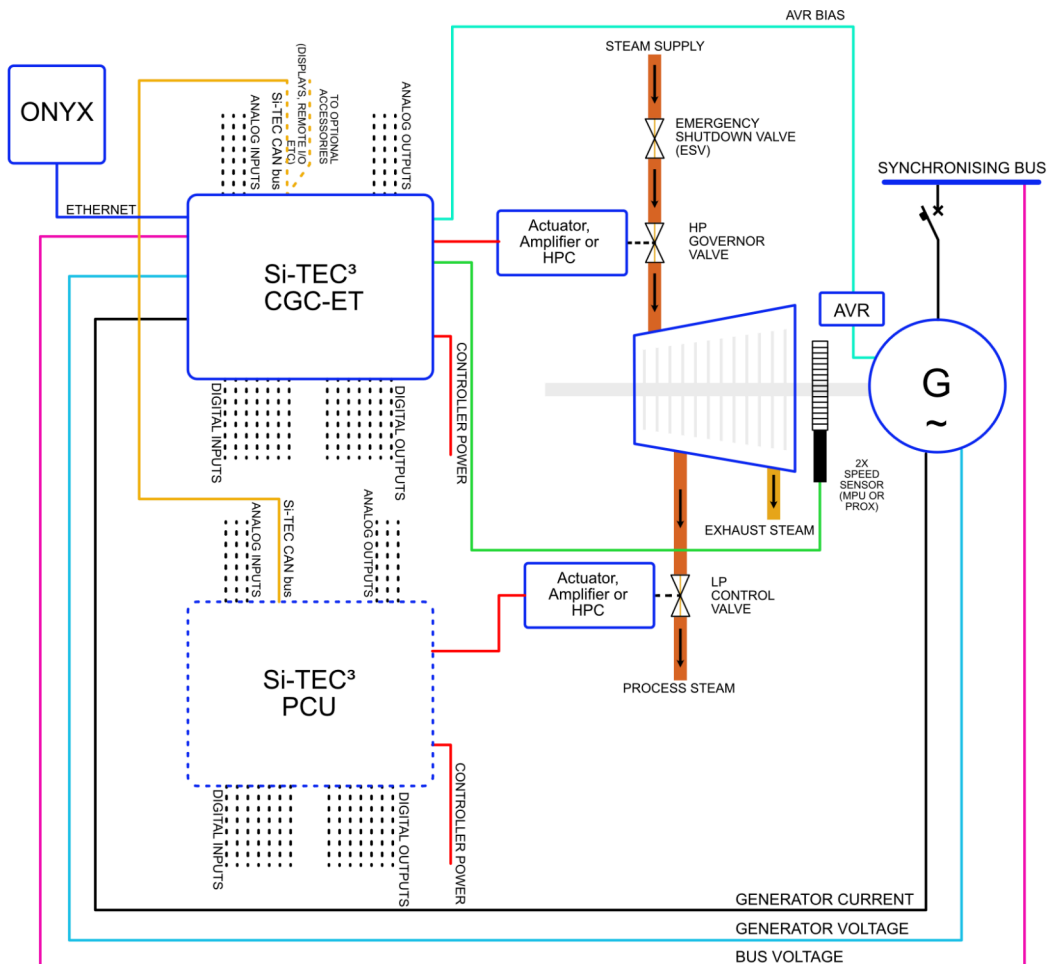

Synchronising

- Digitally integrated with governor
- Better than 10 secs (typically within 5 secs for 0.1 Hz, 1.0 % V & 5° phase match) for most applications
- Phase rotation check during synchronising
- Integrated independent "Sync Check" (3ph bus & gen check) hardware
- Optional "Permissive" synchronising function
- Intelligent "Dead Bus" detection and closure
- Menu adjustable synchronising parameters

Load sharing and load control

- Digitally integrated with governor
- Automatic and isochronous (islanded) kW and kVAr load sharing
- Load sharing accuracy to better than 0.5 %
- True RMS AC measurement (3-phase voltage & current), better than 0.25 % accuracy
- Optimum control of active power (kWs) and reactive power (kVAr/PF) when grid paralleled
- "Bumpless" transfer of active and reactive power
- Mains/grid droop function for large turbine applications
- Process control (e.g. Inlet pressure control)
- Adjustable load/unload ramp rates
- Multi-mode kW & kVAr/power factor control

- AVR bias to directly interface with a wide range of AVRs (digital outputs or +/- 8.4 VDC) for PF sharing/ control
- 4-20 mA and Modbus® RS485 referencing available
- Power factor or kVAr control when base loaded
- Vector disturbance feature senses loss of grid within 40 mSec to maintain full operation of station

Display features via ONYX HMI Touchscreen

- The ONYX HMI touch screen is a dedicated remote display unit for the Si-TEC³ control range (via Ethernet), and has a high-resolution 15" capacitive LCD touch screen allows operators to view real-time turbine and generator information from the Si-TEC³
- Turbine monitoring features including turbine speed, inlet pressure, exhaust pressure, extraction pressure, lube oil pressure, turbine temperature and control voltage
- Metering of all essential generator parameters that include generator voltage, frequency, current, real power, power factor (lag & lead), generator & mains CB statuses. This further reduces the need for conventional meters and transducers
- Live control overview, steam map and start sequence pages showing all current control set points and measured values for improved turbine operation and diagnostics
- Event log for all essential control functions including turbine start/stop, CB status, operator and engineer logins. The entire event log can also be exported via USB in CSV format.

Si-TEC³ CGC-ET turbine used for mains (grid) parallel application

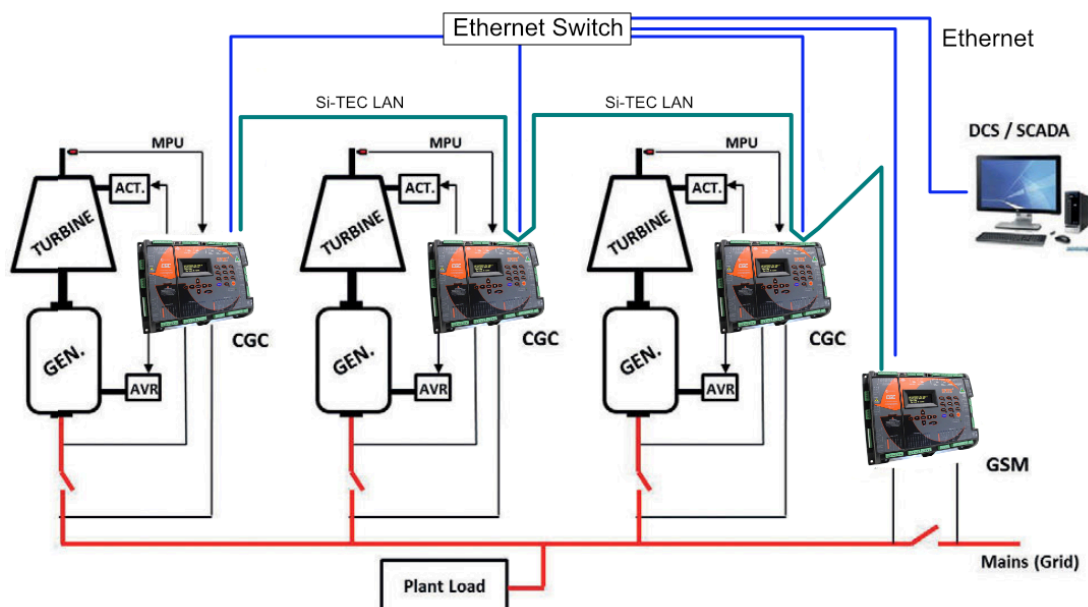

I/O features CGC (including PCU)

- 2 actuator driver outputs (HP & LP actuators)
- 2 x Speed sensor inputs (MPU or Proximity)
- 16 logic inputs (16 via PCU), with LED status indication, of which 28 are user defined for a wide variety of uses, including, "Hot Start", "Sequence Hold", "Speed Raise/Lower", "Voltage Raise/Lower", "Base Load", "Overspeed Test", "Extraction Enabled", "Extraction Priority", etc.
- 11 x relay outputs (9 via PCU), with LED status indication, of which 16 are user defined for a wide range of applications
- 4 x analog inputs [4 via PCU] 4 to 20 mA for user selectable applications. E.g. kW, kVAr, & PF load references, process signal & reference, etc.
- 3 x analog outputs [3 via PCU] 4 to 20 mA for direct driving user applications, E.g. kW, kVAr, PF, RPM meters, actuator position, process reference etc.
- Typical control functions include:
 - "Turbine Started"
 - "AVR Priming"
 - "Synchronising"
 - "Generator C/B" close & trip
 - "kW & kVAr" switches
- Individual output relays can have multiple functions by being assigned as "Combined Alarms"
- Typical alarm functions include:
 - "Speed Sensor" failure
 - "Loss of Actuator Feedback" (Heinzmann Actuators)
 - "Extraction Signal" failure
 - "CAN bus comms" failure (CGC & PCU)
 - "Reverse kW/kVAr" load
 - "High kW/kVAr" load
 - "High/Low Frequency"
 - "High/Low Voltage"
- Each "alarm" can be selected to directly "Trip" the generator C/B

Dimensional Drawing

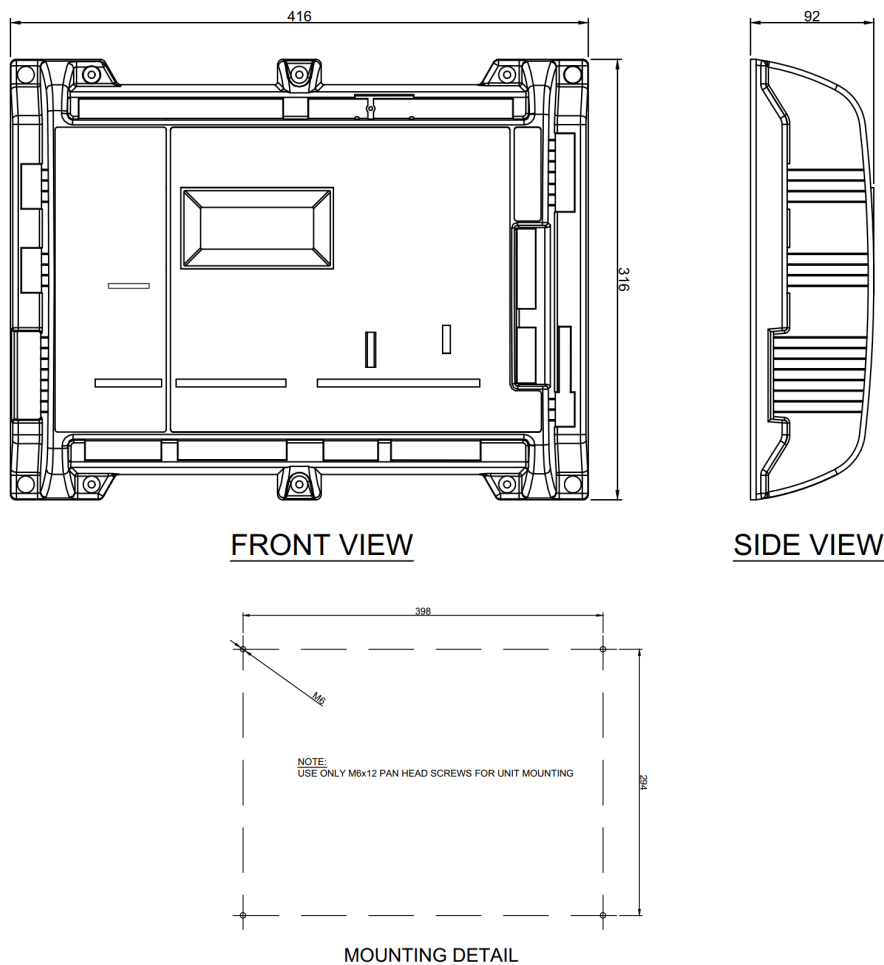

Communications

- Ethernet port using Modbus TCP and/or “Fast Tune” protocol
- “Customer RS485 LAN” has read/write facility for a wide range of registers. Standard LAN protocols are Modbus® RTU and ASCII.
- “Si-TEC LAN” for inter-module communications for up to 24 Si-TEC modules of any type combination
- “CAN Bus” port for CGC to PCU & RIO interface
- RS232 diagnostic port for Si-TEC support

Software tools (Windows based)

Si-TEC pcConfigure

- Allow storage & retrieval of set point parameters to and from a Si-TEC³ module via a PC
- Graphical configuration of steam map and linearisation curves (HP & LP actuators)
- Operates in a safe controlled environment
- Saves all set point parameters to disk
- Data can be sent by email
- Data can be printed for archival records
- Menu driven set-up & alarm configuration
- Software interface via PC or remote access

Si-TEC pcTune

- Allows generator tuning to be performed remotely and in a controlled environment
- Allows generator tuning to be performed with increased accuracy in true engineering values
- Provides 100 % repeatable results
- Recovery characteristics tested by inducing errors and recording results graphically
- 16 traces of user selected digital values can be selected for display
- Multiple PID tuning menus
- Other displays include “Digital Instrument Panel”, “System Overview” and “Live Steam Map”
- Data can be sent by email
- Data can be printed for archival records
- Software interface via PC or remote access

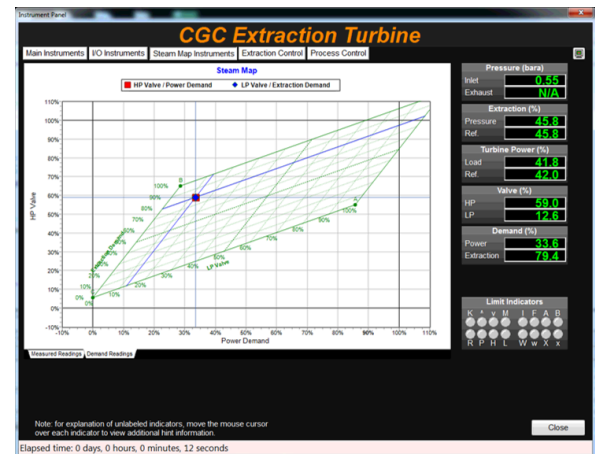
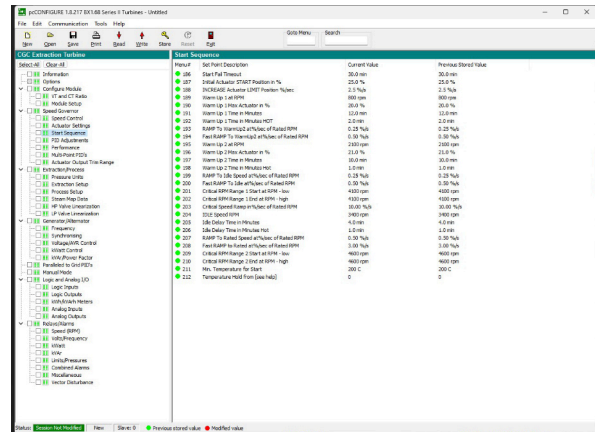
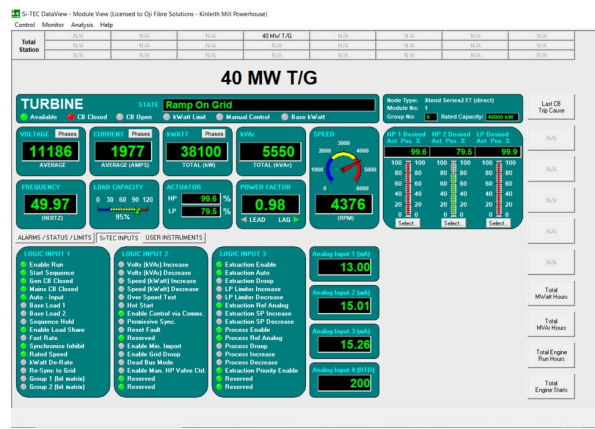

Si-TEC DataView

- High speed power station monitoring system for PC, configurable for up to 24 nodes (including CGC, GSM, ADG, temp scanner, feeders, etc.)
- Includes extensive data logging (up to 100 data per node), event recording, and archiving (up to several years)
- Data extracted via Modbus RS485 or Ethernet (Modbus TCP/IP)
- Exporting of log file via CSV format for up to 20 parameters
- Operates independently of PLC/SCADA

This Page is Intentionally Blank

